

Exporters



imperial

World Trade Pvt. Ltd.

We
Export
Trust

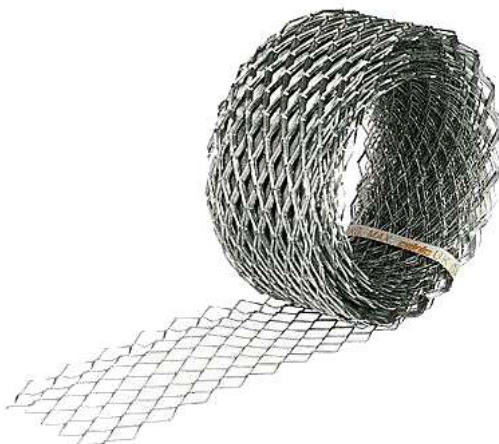

Engineering Spares

INDEX

1) Electric Motor & Gear Box

2) Couplings

3) Sprockets

4) Roller Chain

5) Pulley

6) V-Belts

7) Bearings

8) Hydraulic Jacks

9) Valves

10) Workshop Tools (Hand Tools)

11) Wire Mesh



सत्यमेव जयते

भारत सरकार

GOVERNMENT OF INDIA

वाणिज्य एवं उद्योग मंत्रालय

MINISTRY OF COMMERCE & INDUSTRY

विदेश व्यापार महानिदेशालय

DIRECTORATE GENERAL OF FOREIGN TRADE

मान्यता प्रमाण पत्र

Certificate of Recognition

एक सितारा निर्यात सदन

ONE STAR EXPORT HOUSE

240118000219

मैसर्स.....IMPERIAL WORLDTRADE PRIVATE LIMITED.....

D 303, THE IMPERIAL HEIGHTS,, OPP. BIG BAZAR, 150 FT RING

(आई ई सी ROAD RAJKOT - GUJARAT 360005 पैन

2412007918

AAUCCI8916L)

को विदेश व्यापार नीति, 2015-2020 के प्रावधानों के अनुसार एक सितारा निर्यात सदन का स्तर प्रदान किया जाता है। यह प्रमाण पत्र, प्रक्रिया पुस्तक (2015 -2020) के पैरा 3.20 (बी) में दी गयी शर्तों के निहित.....वर्षों की अवधि के लिए दिनांक से तक वैध होगा।

FIVE

27.07.2018 26.07.2023

M/s IMPERIAL WORLDTRADE PRIVATE LIMITED

D 303, THE IMPERIAL HEIGHTS,, OPP. BIG BAZAR, 150 FT RING

(IEC ROAD RAJKOT - GUJARAT 360005 पैन

2412007918

AAUCCI8916L)

are hereby accorded the status of One Star Export House in accordance with the provisions of the Foreign Trade Policy, 2015-2020. This Certificate is valid for a period of years effective from to subject to the conditions prescribed in Para 3.20(b) of the Hand Book of Procedures (2015-2020).

27.07.2018

26.07.2023

FIVE

सं./No. A/ 5447

तारीख/Date :

स्थान/Place : 20.08.2018

SEAL

Rajkot

(फाइल सं./File No.)

तारीख/Date :

24/21/058/50019/AM19/ 27.07.2018

SUVINDH SHAH
DY. D.G.F.T.अपर/संयुक्त/उप महानिदेशक,
विदेश व्यापार/विकास आयुक्त (एस.ई.झेड.)Additional/ Joint/ Deputy
Director General of Foreign Trade/
Development Commissioner (SEZ)



imperial
World Trade Pvt. Ltd.

Motor & Gear Box

1) Electric Motor

- 1 Phase/3 Phase
- Foot/Flange Mount
- AC/DC



2) Gear Box

- Helical/Bevel/Agitator Gear Box

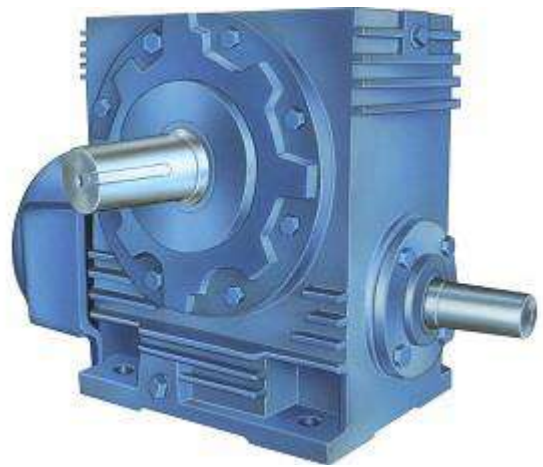

❖ Brands:



Crompton Greaves



❖ Brands:



POWER BUILD PVT LTD



1) Gear Couplings



2) Grid Couplings



3) Roller Chain Coupling



4) Jaw Couplings



5) Sleeve Coupling



6) Tire Coupling



7) Disc Coupling



8) Diaphragm Coupling





1) Double Pitch Sprocket



2) Multiple Strand Sprocket



3) QD (Quick Disconnect) Sprocket



4) Taper-Lock Sprocket



5) Steel Split Sprocket



6) Double Single Sprocket



7) Idler Sprocket



8) Double Plus Sprocket



❖ Sprockets are characterized by type, which indicates hub style

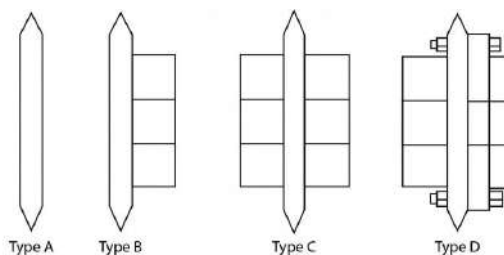

1) Simplex Roller Chain



2) Duplex Roller Chain



3) Triplex Roller Chain



4) Leaf Chain



5) Half Link//Cranked Link



6) Full Links/Master Links/Joint Links



1) Standard Pulley



2) Companion Pulley



3) Idler Pulley



4) Variable Speed Pulley



5) Step Pulley



6) Other Pulley



1) Multi-Groove Belt



2) Ribbed Belt



3) Film Belt



4) Timing Belt



5) Specialty Belt



❖ Brands:



ECONOMY RANGE



imperial
World Trade Pvt. Ltd.

Bearing

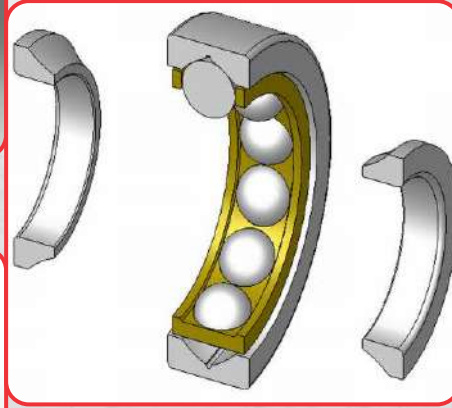



We also deal in all type of Plummer Blocks in series of S, SD, SNA, TVN, SNH, SNL, SAF, SOFN & T.

We also deal in Industrial V-Belts of FENNER (India) LTD.



We also deal in all size of adapter sleeves in J & J and AMB make

We also deal in oil seals with RAJHANS and PIONEER brand.



We also deal in all size of Locknut & Washers of standard manufacturers.



imperial
World Trade Pvt. Ltd.

Hydraulic Jacks

Hydraulic Jacks



Construction - Infrastructure ind.











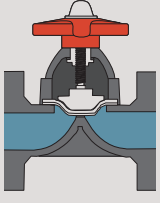
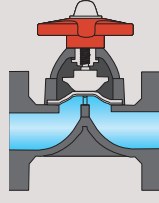

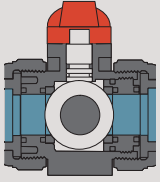
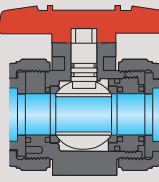

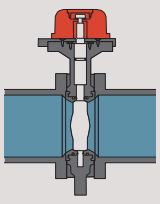
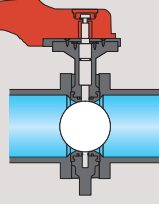
Hydraulic Tools

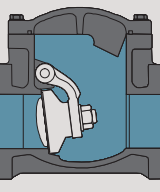
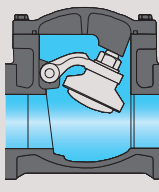

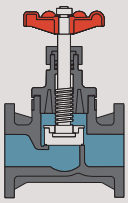
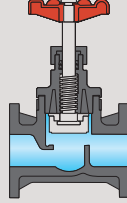
Customized Products

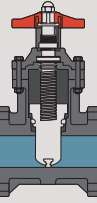
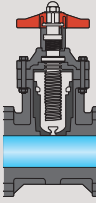

	FULLY CLOSED STATE	FULLY OPEN STATE	INTENDED USE	MANUAL VALVE VALVE TYPE	PHOTO
<p>DIAPHRAGM VALVE</p> <p>OPENS AND CLOSES THE GATE AT THE CENTER OF THE VALVE BY MOVING UP AND DOWN THE DIAPHRAGM.</p> <ul style="list-style-type: none"> • THE FLOW MAY BE EITHER FROM THE RIGHT OR LEFT. 			<ul style="list-style-type: none"> • INSULATES THE WETTED PART FROM LOW-CONTAMINATION GREASE AND METAL PARTS • FLOW RATE CONTROL • SLURRY FLUID 	ROUND HANDLE TYPE	
<p>BALL VALVE</p> <p>OPENS AND CLOSES THE FLOW PATH BY TURNING THE SPHERICAL VALVE ELEMENT 90°.</p> <ul style="list-style-type: none"> • IN PRINCIPLE, THE FLOW MAY BE EITHER FROM THE RIGHT OR LEFT. • THE FLOW IS STRAIGHT. 			<ul style="list-style-type: none"> • LOW PRESSURE LOSS • SWITCHING OF FLOW DIRECTION (3 WAY BALL VALVE) • ON-OFF 	LEVER TYPE	
<p>BUTTERFLY VALVE</p> <p>OPENS AND CLOSES THE FLOW PATH BY TURNING THE DISC VALVE ELEMENT 90°.</p> <ul style="list-style-type: none"> • THE FLOW MAY BE EITHER FROM THE RIGHT OR LEFT. • ALTHOUGH DIVIDED INTO TWO BY THE VALVE ELEMENT, THE FLOW IS ALMOST STRAIGHT. 			<ul style="list-style-type: none"> • LARGE FLOW RATE • SPACE SAVING • SLURRY FLUID • LOW PRESSURE LOSS • FLOW RATE CONTROL 	LEVER TYPE GEAR TYPE	
<p>SWING CHECK VALVE</p> <p>BACKWARD FLOW OF THE FLUID MAKES THE VALVE ELEMENT PRESSED ONTO THE VALVE SEAT, WHICH PREVENTS BACKFLOW.</p> <ul style="list-style-type: none"> • THE DIRECTION OF FLOW IS FIXED. • THE FLOW IS ALMOST STRAIGHT. 			<ul style="list-style-type: none"> • BACK-FLOW PREVENTION 	—	
<p>STOP VALVE (GLOBE VALVE)</p> <p>THE VALVE ELEMENT SHUTS OFF THE FLUID TO CONTROL OPEN AND CLOSE.</p> <ul style="list-style-type: none"> • THE DIRECTION OF FLOW IS FIXED. • THE FLOW FORMS AN S SHAPE. 			<ul style="list-style-type: none"> • HIGH ACCURACY CONTROL 	ROUND HANDLE TYPE	
<p>GATE VALVE</p> <p>THE VALVE ELEMENT BLOCKS THE FLUID PASSAGE PERPENDICULARLY TO CONTROL OPEN AND CLOSE.</p> <ul style="list-style-type: none"> • THE FLOW MAY BE EITHER FROM THE RIGHT OR LEFT. • THE FLOW IS STRAIGHT. 			<ul style="list-style-type: none"> • LOW PRESSURE LOSS • ON-OFF 	ROUND HANDLE TYPE CAP TYPE	



imperial
World Trade Pvt. Ltd.

Workshop Tools (Hand Tools)



One Stop Solutions..

1	Wrenches		
2	Sockets with accessories		
3	Pliers		
4	Insulated tools		
5	Plumbing tools		
6	Shears		
7	Screwdrivers		
8	Pullers		
9	Hammers, punches and chisels		
10	Workshop equipment		
11	Pneumatic tools and accessories		
12	Measuring tools		
13	Tools for electronic		
14	Automotive tools		
15	Tools for bicycle service		
16	Vices, saws, files, wheels, knives..		
17	Set of tools		
18	Marketing materials		



imperial
World Trade Pvt. Ltd.

Wire Mesh

CRIMPED MESHES

Heaviest 1" Rod (25 mm) thick in Spring-Steel, Stainless Steel, High Carbon - High Tensile, G.I / M.S., Etc.

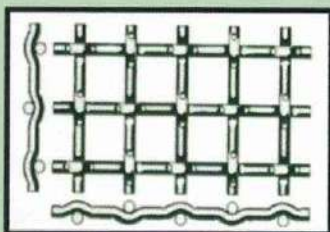

WELDED WIRE MESH / FABRICS

These are Mfrd & Supplied in M.S./G.I., Stainless steel in different widths & Required size mesh & gauge. ALSO ANGULAR / DEGREE

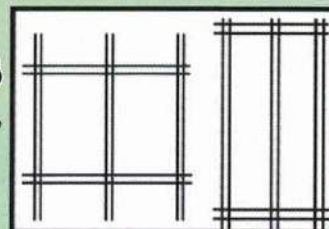

VIBRATING WIRE WOVEN SCREENS (WITH/WITHOUT PANELS)

Plain ends or with side panels Mfrd to the Reqd. Sizes, aperature, dia in diff. Metals S.S./ Spring Steel, G.I./M.S., High Carbon, High Tensile etc. Correct to Cht sizes, ALSO VIBRATING MACHINES

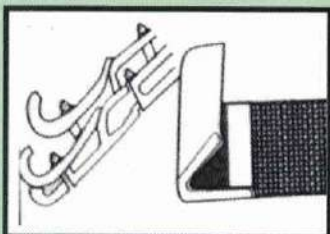

EXPANDED METALS

Are kept in M.S./ ALUMINUM / G.I. Stainless Steel of fine biggest holes & in different thickness, widths, Strands etc. Supplied in different sizes & widths, also Flattened Expanded Metals.

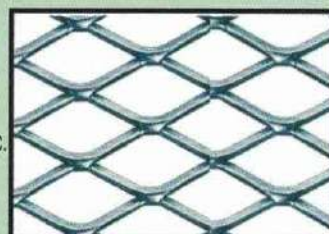

AIR CLEANER KNIT -MESH

Mfrd. In Stainless steel Copper, Aluminium, GID/G.O./ Nylon of diff. Widths & Sizes.

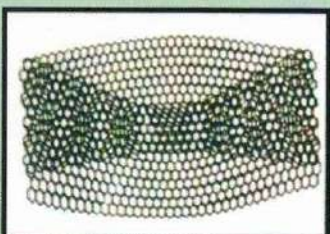

MIST FLIMINATOR DEMISTER PADS

These are Mfrd Mostly in S.S. wire with S.S. Grid Frames to the Reqd Sizes for the Separation of Mist & Entrained Liquid from vapour stream

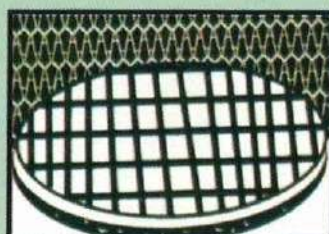

EXTRA - HEAVY (up to 20 mm Thick Rod)

Wire Meshes in S.S./G.I./P.B./ Spring-Steel /M.S./ Aluminium, Brass, Copper Filter-Cloth etc., Mfd & Supliend in cut to Size in Rectangular Mesh, Hollander Mesh, Dutch Weave palin Weave, Twill Weave, Five Shaft Weave and Other Type of Weaves.

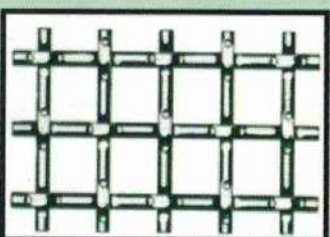

FINE MESHES

In Stainless steel, G.I., GID., Stainless Steel, P.B. Brass Copper, Nylon, etc. , As per ISS/BSS/ASTM/ Tyler upto the finest Microns & Meshes.

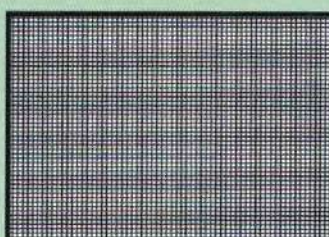

CHAINLINK WIRE FENCINGS

Mfrd In G.I./PVC Coated & Stainless Steel from 6 G to 18 G of any height / widths to the required leangth & Sizes.



CHICKEN POULTRY HEX-NETTINGS

Mfrd :- From 3/8" mesh 2" mesh from 18g to 30g in Gid, G.I. Stainless Steel, P.V.C. Coated up to 6' Ft., (1.8 mts.,) Widths



Wiremesh Specification

Mesh	SWG	DIAMETER OF WIRE		SIZE OF OPENING			Approx Percentage Open Area	Mesh	SWG	DIAMETER OF WIRE		SIZE OF OPENING			Approx Percentage Open Area
				Inch	MM	Micron						Inch	MM	Micron	
		Inch	MM							Inch	MM				
4	12	0.104	2.640	0.146	3.170	3,170	34.14	18	25	0.020	0.500	0.036	0.911	911	41.69
4	13	0.092	2.340	0.158	4.010	4,010	39.98	18	26	0.018	0.450	0.038	0.961	961	46.39
4	14	0.080	2.030	0.170	4.320	4,320	46.28	18	27	0.016	0.400	0.040	1.011	1,011	51.34
4	15	0.072	1.830	0.178	4.520	4,520	50.67	18	28	0.015	0.370	0.041	1.041	1,041	54.43
4	16	0.064	1.630	0.186	4.720	4,720	55.25								
4	17	0.056	1.430	0.194	4.920	4,920	60.03	20	24	0.022	0.550	0.028	0.720	720	32.14
4	18	0.048	1.220	0.202	5.130	5,130	65.27	20	25	0.020	0.500	0.030	0.770	770	36.76
								20	26	0.018	0.450	0.032	0.820	820	41.69
								20	27	0.016	0.400	0.034	0.870	870	46.93
								20	28	0.015	0.370	0.035	0.900	900	50.22
								20	29	0.013	0.340	0.037	0.930	930	53.62
								20	30	0.012	0.310	0.038	0.960	960	57.14
5	14	0.080	2.030	0.120	3.050	3,050	36.05								
5	15	0.072	1.830	0.128	3.250	3,250	40.93	24	27	0.016	0.400	0.026	0.658	658	38.69
5	16	0.064	1.630	0.136	3.450	3,450	46.12	24	28	0.015	0.370	0.027	0.688	688	42.30
5	17	0.056	1.430	0.144	3.650	3,650	51.62	24	29	0.013	0.340	0.028	0.718	718	46.07
5	18	0.048	1.220	0.152	3.860	3,860	57.74	24	30	0.012	0.310	0.029	0.748	748	50.00
5	19	0.040	1.020	0.160	4.060	4,060	63.87	24	32	0.011	0.270	0.031	0.788	788	55.48
5	20	0.036	0.910	0.164	4.170	4,170	67.38								
6	16	0.064	1.630	0.102	2.603	2,603	37.82	30	28	0.015	0.370	0.019	0.477	477	31.70
6	17	0.056	1.430	0.110	2.803	2,803	43.85	30	29	0.013	0.340	0.020	0.507	507	35.81
6	19	0.040	1.020	0.127	3.213	3,213	57.62	30	30	0.012	0.310	0.021	0.537	537	40.18
6	20	0.036	0.910	0.131	3.323	3,323	61.63	30	31	0.011	0.290	0.022	0.557	557	43.23
6	21	0.032	0.810	0.135	3.423	3,423	65.39	30	32	0.011	0.270	0.023	0.577	577	46.39
8	16	0.064	1.630	0.061	1.545	1,545	23.68	40	32	0.011	0.270	0.014	0.365	365	33.04
8	17	0.056	1.430	0.069	1.745	1,745	30.21	40	33	0.010	0.250	0.015	0.385	385	36.76
8	18	0.048	1.220	0.077	1.955	1,955	37.91	40	34	0.009	0.234	0.016	0.401	401	39.88
8	19	0.040	1.020	0.085	2.155	2,155	46.07	40	35	0.008	0.210	0.017	0.425	425	44.80
8	20	0.036	0.910	0.089	2.265	2,265	50.89	40	36	0.008	0.193	0.017	0.442	442	48.45
8	21	0.032	0.810	0.093	2.365	2,365	55.48								
8	22	0.028	0.710	0.097	2.465	2,465	60.28	50	34	0.009	0.234	0.011	0.274	274	29.09
8	23	0.024	0.610	0.101	2.565	2,565	65.27	50	35	0.008	0.210	0.012	0.298	298	34.41
8	24	0.022	0.550	0.103	2.625	2,625	68.36	50	36	0.008	0.193	0.012	0.315	315	38.45
8	25	0.020	0.500	0.105	2.675	2,675	70.98	50	37	0.007	0.172	0.013	0.336	336	43.75
								50	38	0.006	0.152	0.014	0.356	356	49.11
10	20	0.036	0.910	0.064	1.630	1,630	41.18	60	36	0.008	0.193	0.009	0.230	230	29.60
10	21	0.032	0.810	0.068	1.730	1,730	46.39	60	37	0.007	0.172	0.010	0.251	251	35.25
10	22	0.028	0.710	0.072	1.830	1,830	51.91	60	38	0.006	0.152	0.011	0.271	271	41.08
10	23	0.024	0.610	0.076	1.930	1,930	57.74								
10	24	0.022	0.550	0.078	1.990	1,990	61.38	80	38	0.006	0.152	0.007	0.166	166	27.17
10	25	0.020	0.500	0.080	2.040	2,040	64.50	80	39	0.005	0.130	0.007	0.188	188	34.88
12	22	0.028	0.710	0.055	1.407	1,407	44.16	80	40	0.005	0.122	0.008	0.196	196	37.91
12	23	0.024	0.610	0.059	1.507	1,507	50.67	80	41	0.004	0.112	0.008	0.206	206	41.89
12	24	0.022	0.550	0.062	1.567	1,567	54.78	80	42	0.004	0.102	0.008	0.216	216	46.07
12	25	0.020	0.500	0.064	1.617	1,617	58.34								
12	26	0.018	0.450	0.066	1.667	1,667	62.00	100	42	0.004	0.102	0.006	0.152	152	35.81
14	24	0.022	0.550	0.050	1.264	1,264	48.56	100	43	0.004	0.091	0.006	0.163	163	41.18
14	25	0.020	0.500	0.052	1.314	1,314	52.48	100	44	0.003	0.081	0.007	0.173	173	46.39
14	26	0.018	0.450	0.054	1.364	1,364	56.55	120	44	0.003	0.081	0.005	0.131	131	38.11
14	27	0.016	0.400	0.056	1.414	1,414	60.77	150	45	0.003	0.071	0.004	0.098	98	33.72
14	28	0.015	0.370	0.057	1.444	1,444	63.37	150	45.5	0.002	0.063	0.004	0.106	106	39.43
16	24	0.022	0.550	0.041	1.038	1,038	42.71	200	47	0.002	0.050	0.003	0.077	77	36.76
16	25	0.020	0.500	0.043	1.088	1,088	46.93	250	48	0.002	0.040	0.002	0.062	62	36.76
16	26	0.018	0.450	0.045	1.138	1,138	51.34	300	48	0.002	0.040	0.002	0.045	45	27.83
16	27	0.016	0.400	0.047	1.188	1,188	55.96	325	48.5	0.001	0.035	0.002	0.043	43	30.49
16	29	0.013	0.340	0.049	1.248	1,248	61.75	400	49.5	0.001	0.028	0.001	0.036	36	31.25
16	30	0.012	0.310	0.050	1.278	1,278	64.76	500	50	0.001	0.025	0.001	0.026	26	25.79

imperial

World Trade Pvt. Ltd.



Corporate address :

D-303, The Imperial Heights,
Opp. Big Bazaar, 150 ft. Ring Road,
Rajkot - 360005 Dist: Rajkot,
GUJARAT-INDIA

Web : www.imperialworldtrade.com
Email : info@imperialworldtrade.com
Skype : imperialworldtrade
Cell : +91 94277 26335 (24 X 7)